

**Board of County Road Commissioners
County of Ingham, State of Michigan**

301 Bush Street, P.O. Box 38

Mason, Michigan 48854

Ph.: (517) 676-9722

Fax: (517) 676-2085

www.inghamcrc.org

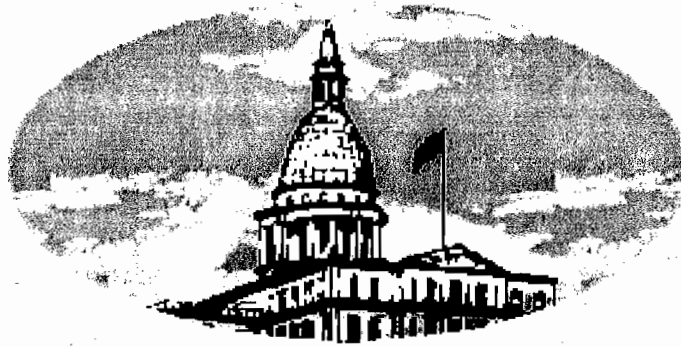

**Rules, Standards and Procedures for
Driveways, Banners and Parades
Upon or Over
Ingham County Road Commission
Right of Way**

January 2006

**BOARD OF COUNTY ROAD COMMISSIONERS
OF THE COUNTY OF INGHAM**

Austin E. Cavanaugh Administration Building
301 Bush Street, P.O. Box 38
Mason, Michigan 48854-0038

This publication contains the rules, standards and procedures for driveways, banners and parades upon or over the public roads, which are under the jurisdiction of the Board of County Road Commissioners of the County of Ingham, State of Michigan. This publication supersedes the publication of December 1, 1994.

Pursuant to Act No. 200 of the Public Acts of 1969, of the State of Michigan, the Board of County Road Commissioners of the County of Ingham, Michigan, herewith adopts the following specifications and administrative rules governing the issuance of a permit for the placing of driveways, installation of banners and closures of highways for parades, festivals or celebrations within the right of way of any road under the jurisdiction of this Board.

Adopted by the Board of Ingham County Road Commissioners on September 25, 2003, and revised on January 3, 2006.

TABLE OF CONTENTS

| | | |
|---------------|--------------------------------------------------------------|-----------|
| PART 1 | GENERAL PROVISIONS | 1 |
| | 1.1 Permits Required | 1 |
| | 1.2 Definitions | 4 |
| | | |
| PART 2 | DRIVEWAY PERMITS | 10 |
| | 2.1 Authorized Applicants | 10 |
| | 2.2 Applications for Permits | 10 |
| | 2.3 Requirements for Plans of Proposed Driveway(s) | 11 |
| | 2.4 Permit Application Review Procedure | 13 |
| | 2.5 Design and Placement Requirements | 15 |
| | 2.6 Conditions of Issuance of Driveway Permits | 15 |
| | 2.7 Indemnity and Certificates of Insurance | 17 |
| | 2.8 Permit Deposits | 17 |
| | 2.9 Bonds | 18 |
| | 2.10 Appeals and Variance Procedures for Permit Applications | 18 |
| | | |
| PART 3 | DRIVEWAY DESIGN STANDARDS | 20 |
| | 3.1 Number of Driveways | 20 |
| | 3.2 Number of Ingress Lanes | 21 |
| | 3.3 Number of Egress Lanes | 21 |
| | 3.4 One-Way Access | 21 |
| | 3.5 Driveway Locations | 22 |

| | | |
|---------------|-------------------------------------------------|-----------|
| 3.6 | Commercial Driveway Spacing | 22 |
| 3.7 | Property Clearance | 24 |
| 3.8 | Corner Clearance | 24 |
| 3.9 | Clear Vision Areas | 25 |
| 3.10 | Buffer Areas | 26 |
| 3.11 | Sight Distance | 26 |
| 3.12 | Driveway Dimensions and Details | 29 |
| 3.13 | Commercial Driveways | 30 |
| 3.14 | Residential Driveways | 33 |
| 3.15 | Field Entrances and Utility Structure Driveways | 34 |
| 3.16 | Driveway Surfacing | 34 |
| 3.17 | Curbing | 36 |
| 3.18 | Drainage | 37 |
| 3.19 | Driveway Profile | 38 |
| 3.20 | Parking and Storage | 39 |
| 3.21 | Traffic Signing | 39 |
| 3.22 | Traffic Signals | 39 |
| 3.23 | Traffic Impact Study | 41 |
| PART 4 | BANNER PERMITS | 46 |
| 4.1 | Authorized Applicants | 46 |
| 4.2 | Application Forms | 46 |
| 4.3 | Minimum Requirements | 46 |

| | | |
|---------------|--------------------------------------------------------------|-----------|
| 4.4 | Design and Placement Requirements | 47 |
| 4.5 | Conditions of Issuance of Banner Permits | 48 |
| PART 5 | ROAD CLOSURES FOR PARADES, CELEBRATIONS AND FESTIVALS | 49 |
| 5.1 | Authorized Applicants | 49 |
| 5.2 | Application Forms | 49 |
| 5.3 | Minimum Requirements | 49 |
| 5.4 | Road Closure Permit Conditions | 50 |

TABLES

| | | |
|----------|----------------------------------|----|
| TABLE 1: | Commercial Driveway Spacing | 23 |
| TABLE 2: | Property Clearance Requirements | 24 |
| TABLE 3: | Corner Clearance | 25 |
| TABLE 4: | Sight Distance – Two Lane Roads | 27 |
| TABLE 5: | Sight Distance – Four Lane Roads | 28 |
| TABLE 6: | Sight Distance – Five Lane Roads | 28 |

EXHIBITS

| | | |
|------------|----------------------------------------------------|----|
| EXHIBIT 1: | Two-Way Commercial Driveway Dimensions | 54 |
| EXHIBIT 2: | One-Way Commercial Driveway Dimensions | 55 |
| EXHIBIT 3: | Divided Commercial Driveway Dimensions | 56 |
| EXHIBIT 4: | Warrants for Right Turn Deceleration Lane or Taper | 57 |
| EXHIBIT 5: | Commercial Right Turn Lane and Taper | 58 |

| | |
|------------------------------------------------------------|----|
| EXHIBIT 6: Warrant for Left Turn Passing Lane | 59 |
| EXHIBIT 7: Passing Lane and Taper Lane | 60 |
| EXHIBIT 8: Residential Driveway | 61 |
| EXHIBIT 9: Residential Driveway – Subdivision | 62 |
| EXHIBIT 10: Field Entrance and Utility Structure Driveways | 63 |

PART 1 – GENERAL PROVISIONS

Rule 1.1 Permit Required

(1) Subsequent to the effective date of these rules, no person, organization or governmental unit shall undertake or conduct any of the following activities on or along county roads within the county right of way unless a permit to allow such activity shall have been obtained from the Ingham County Road Commission Permit Department.

(a) construction, reconstruction, surfacing or resurfacing a driveway;

(b) engage in a use of the land served by the driveway which is changed or expanded from that previously existing and the existing driveway does not meet the current standards or the driveway is a safety hazard, subject to Paragraph (3) and (4) below;

(c) land division;

(d) operate, use or maintain a new driveway;

(e) erect or suspend a banner, decoration, or similar object;

(f) close a section of a county road to normal traffic for the purpose of staging a parade, celebration, festival or similar activity.

(2) Construction of a new driveway or private road connecting to a county road or reconstruction of a driveway or private road connecting to a county road shall be allowed only after an approved permit has been obtained from the Permit Department. The construction or reconstruction of all driveways or private roads shall be as described in an approved permit, and plans or drawings accompanying the permit. The County

Engineer, or his/her appointed agent must approve significant changes in plans.

(3) When the use of the land served by the driveway is changed or expanded and the existing driveway does not meet current standards or is a safety hazard, the driveway will be considered a new driveway as per Act 83, Public Acts of 1978. Factors that constitute a safety hazard shall include, but are not limited to, the following:

- (a) increased accident rate at or near the driveway;
- (b) increased traffic volume on the main road;
- (c) increased turning movements at the driveway;
- (d) improper drainage;
- (e) inadequate sight distance at the driveway;
- (f) excessive grades on the driveway;
- (g) improper driveway design for use;
- (h) creates a foreseeable risk of harm to the traveling public.

(4) Any proposed use of land that requires a permit from the local land use body shall be deemed to be a changed or expanded use of the land. When the use of the land served by the driveway is changed or expanded, the driveway will be considered a new driveway. Whenever any existing use of land has been discontinued for three (3) consecutive months, or for nine (9) months during any three-year period, such discontinuance shall be considered conclusive evidence of an intention to abandon that use. Thereafter, land shall be considered as if vacant.

(5) If, upon inspection, a driveway or private road approach constructed or reconstructed after the effective date of these rules is found

to be in violation of these rules, the owner shall correct any deficiencies within a period of time of not more than 30 days, specified in a notice of violation sent by certified mail to the owner. Dangerous or hazardous conditions shall be corrected immediately. If the owner fails to make the necessary corrections within the period of time stated in the notice, the Road Commission, or its agents, may perform the necessary correction(s), with the costs incurred, and administrative fees, to be reimbursed to the Road Commission by the owner.

(6) In the event of failure to comply with the terms and conditions of any permit issued in accordance with these rules, or failure to obtain an appropriate permit, the Ingham County Road Commission shall have the right to halt the ingress and egress activity of the site until such time as adequate corrections have been made. All costs incurred by the Road Commission in correcting any failure to comply with conditions and standards of a permit, failure to obtain a permit, or if there is defective workmanship or defective materials, this cost shall be borne by the applicant, or the person undertaking the activity.

(7) Permit forms are available at the Permit Department office of the Ingham County Road Commission at 301 Bush Street, P.O. Box 38, Mason, Michigan, 48854-0038.

Rule 1.2 Definitions

(1) **AASHTO:**

The current edition of the American Association of State Highway and Transportation Officials, "A Policy on Geometric Design of Highways and Streets."

(2) **ADT:**

Average Daily Traffic.

(3) **Applicant:**

Property owner or the property owner's authorized legal agent who is applying for a permit to connect a driveway as defined by Section 1 of Act 200 of the Public Acts of 1969, as amended, with a county road. The term also includes governmental agencies applying for a permit to temporarily close a county road for a parade, celebration, festival or similar activity authorized by Act 200 of the Public Acts of 1969, as amended.

(4) **Arterial:**

Any road with an ADT volume of 10,000 vehicles or more.

(5) **Banner:**

Any arrangement of words, lettering, symbols or decorative device, including Christmas decorations, suspended over any portion of a road or adjacent to a travel lane.

(6) **Board:**

The Board of County Road Commissioners of the County of Ingham, State of Michigan, a Public Corporate Body.

(7) **Buffer Area:**

An area of the public right of way adjacent to a roadway that serves as a physical barrier to vehicular travel between road traffic and activity on the private property.

(8) **Circle Driveway:**

A private driveway that enters and leaves private property at two points within the same frontage.

(9) **Clear Vision Area:**

Land acquired or used by and in accordance with standard practices of the agency having jurisdiction over a road for the purpose of maintaining unobstructed vision.

(10) **Commercial Driveway:**

A driveway serving a commercial establishment, industry, governmental or educational institution, hospital, church, apartment building, mobile home park and all other facilities not included in the definitions for residential, field or utility structure driveways.

(11) **Collector:**

Any road with an ADT volume of 5,000 to 10,000 vehicles.

(12) **County Engineer**

The Managing Director, the Director of Engineering, the Director of Traffic and Safety or other representative designated by the Board of Ingham County Road Commissioners.

(13) **Directional Driveway:**

A driveway system designed so that traffic leaving the road is separated from and does not conflict with traffic entering the road (with critical turning movements to and from the property restricted) at certain access points.

(14) **Divided Driveway:**

A driveway so designed that traffic entering the driveway is separated by a traffic island from the traffic leaving the driveway.

(15) **Field Driveway:**

Any driveway serving a farmyard, cultivated or uncultivated field, timberland or undeveloped land not used for industrial, commercial or residential purposes.

(16) **Frontage:**

The private property line that abuts the road right of way.

(17) **Licensee:**

A person, partnership or corporation under the authority, control and responsibility of the applicant to perform the work requested by the applicant in accordance with the requirements set forth in these rules and those of Act 200 of the Public Act of 1969, as amended.

(18) **Limited Access:**

Road right of way in respect to which owners or occupants of abutting lands, and other persons, have no legal right to access to or from the same abutting lands except at such point only, and in such manner as determined by the public authority having jurisdiction over such road, street or highway.

(19) **Local Road:**

Any road with an ADT of less than 5,000 vehicles.

(20) **Michigan Department of Transportation Standard Specifications for Construction:**

The current Michigan Department of Transportation Standard Specifications for Construction that shall also include the current Michigan Department of Transportation Supplementary Specifications and Design Standards on file at the Permit Department, and any other standards published for design use by a recognized authority and accepted for use by the Ingham County Road Commission.

(21) **MMUTCD:**

The current edition of the Michigan Manual of Uniform Traffic Control Devices.

(22) **Owner's Engineer:**

The professional engineer or architect registered in the State of Michigan who is employed by the property owner to prepare plans and supervise construction.

(23) **Permit Department:**

The Permit Department of the Ingham County Road Commission.

(24) **Permit Holder:**

The individual who applies for and obtains a permit.

(25) **Private Road:**

A road that is not under the jurisdiction of a public body and serves more than two businesses or homes.

(26) **Property Owner:**

A natural person, firm, association, partnership, corporation, or combination of any of these, or any other party having an interest in the land involved.

(27) **Reasonable and/or Reasonableness:**

As used herein and as applicable to the standards set forth herein, the determination of reasonable and reasonableness resides in the sole discretion of the Board of Ingham County Road Commissioners, whose determination shall be final.

(28) **Residential Driveway:**

A driveway serving a private one-family or two-family dwelling.

(29) **Resolution:**

A resolution passed by a local governing body authorizing a specific official or officials to apply to the Ingham County Road Commission for an individual permit, or for all permits in the case of a blanket resolution, and wherein the governing body agrees to indemnify and hold harmless all persons from claims of every kind arising out of operations authorized by such permit(s) as is (are) issued.

(30) **Right of Way:**

The land over which the Ingham County Road Commission has highway jurisdiction and which is subject to use for highway purposes.

(31) **Right of Way Line:**

The boundary between private property and the public lands under the legal control of the agency having jurisdiction over a road.

(32) **Road Commission:**

As referred to in this text, the Ingham County Road Commission.

(33) **Sight Distance:**

The length of clear view along a highway required so that a specified object is visible to the driver, or the required distance of clear vision required when safely entering or crossing a county road.

(34) **Stabilized Gravel:**

Michigan Department of Transportation's 22A or 23A gravel or equivalent.

(35) **Temporary Approach:**

A point of access that will be used for a particular purpose for a specified short period of time not to exceed one year. After said period of time, either a permanent approach permit must be acquired and the approach built or the approach must be removed and the right of way restored to its original condition.

(36) **Utility Structure Driveway:**

Any driveway serving a structure or utility installation such as a pump house or substation that operates automatically and requires only occasional access.

PART 2 – DRIVEWAY PERMITS

Rule 2.1 Authorized Applicants

Any person, organization or governmental unit desiring to construct, reconstruct, relocate or resurface a driveway within the Ingham County Road Commission right of way shall make application and secure a permit before beginning construction. Platted street approaches shall be governed by the Ingham County Road Commission's ***Procedures and Guidelines for Developing Public Roads***. The acceptable applicants for driveway permits are property owners or agents, or a contractor employed by the property owner. However, the owner or his/her agent and the contractor may be required to sign the permit.

Rule 2.2 Applications for Permit(s)

(1) Applications for driveway permits shall be submitted in the manner prescribed by and on the appropriate forms supplied by the Permit Department. Commercial driveway applications shall be accompanied by three (3) sets of plans or drawings containing the information required by Rule 2.3 of these Rules, and which shall include design standards for all proposed driveways in conformance with the requirements of Part 3 of these Rules.

(2) Applications should be submitted as early as possible. In case of new commercial developments, the Ingham County Road Commission Director of Engineering should be contacted in the initial site planning stages so that a preliminary access plan satisfactory to all parties can be established early in the development process. This access plan will include satisfactory storm drainage outlets, proper driveway locations and

will consider the relationship between parking and storage facilities and other development in the vicinity, either on private property or on public right of way.

(3) The permit is fully executed and in force after the plans are approved and the permit signed by the owner or his/her agent, the contractor and the Managing Director of the Ingham County Road Commission.

Rule 2.3 Requirements on Plans of Proposed Commercial Driveway(s)

All copies of commercial driveway permit applications shall be accompanied by two (2) sets of plans, or drawings, clearly indicating the following features as the Ingham County Road Commission may require:

(a) Existing road pavement, ditches, right of way and property lines, road appurtenances, medians (if existing) and dimensions thereof, and driveways on adjacent property and on property opposite the frontage and names of existing and proposed roads.

(b) All buildings, both proposed and existing, and all appurtenances to any business being conducted and dimensions thereof including a notation as to present or proposed use of the buildings.

(c) Design standards (in accordance with Part 3 of these Rules) of all driveways, tapers and right turn and passing lanes to be constructed, reconstructed, relocated, surfaced, resurfaced, operated, used or maintained to include the following dimensions and features:

- widths of all driveways;

- radii of driveway returns and other points of curvature;
- driveway grades or profile view of driveway;
- road centerline and edge of pavement grades;
- angle of the driveway(s) relative to the roadway centerline;
- dimensions of roadside control island and other traffic islands adjacent to the road;
- driveway surface material and traffic island surface material; and
- sight distance for the approach.
- topography of the property before and after.

(d) Distance from existing driveway(s) and proposed driveway(s), distance to the nearest intersecting street, and distance from driveways to property lines.

(e) All roadside features, in addition to driveways, to be constructed within the road right of way including roadside control island, curb, sidewalks, authorized traffic signs and other roadside features such as manholes and poles.

(f) Existing and proposed drainage structures and controls to include:

- size of drive culverts;
- type of culvert;
- material of culvert;
- type of culvert end treatment;

- grade of culvert with sufficient elevations upstream and downstream to show the extent of flow across the proposed development and to the proposed outlet;
- direction of surface water flow on and from adjacent property;
- drainage structures;
- drainage from adjacent parking or storage areas or private property may not be discharged onto the highway or its appurtenances.

(g) North directional arrow and scale of drawing.

(h) The above requirements, when applicable, should be incorporated with appropriate guidelines from Exhibits 1 to 10 to form a complete plan for permit applications.

Rule 2.4 Permit Application Review Procedures

(1) A review period begins with the acceptance of a permit application by the Ingham County Road Commission.

(2) Upon acceptance of the application permit and supplemental information, the Road Commission shall use this document and any other applicable state statutes for evaluating and acting on the application. The Road Commission will work cooperatively with the applicant in an attempt to resolve all difficulties prior to taking final action on the application. Normally, the application will be processed within 10 working days. Transmittal of a completed permit, approved by the Road Commission, or

transmittal of a denied application constitutes action on the permit application.

(3) Requests for variance from the standards of this regulation may be submitted to the Road Commission and shall be considered an attachment to the permit application. The review of variance requests shall be in accordance with Rule 2.1. Variance procedures may be used when the design standards of this regulation are not entirely applicable to the proposed request for access. The Road Commission or the applicant may request a meeting to discuss reasons for denial.

(4) If the Road Commission denies an application, the Road Commission shall provide the applicant a copy of the application marked "denied" along with any attachments and a written explanation for the decision.

(5) If the Road Commission approves an application permit, the permit shall be prepared and transmitted to the applicant along with any additional terms and conditions established by the review. The owner noted on the permit, normally the property owner, will become the permit holder. If the permit holder does not agree to all terms and conditions of the permit, the permit shall be deemed denied.

(6) The issue date of the permit is the date the Managing Director of the Ingham County Road Commission, or the Ingham County Road Commission Board, if appealed, signs the permit.

(7) The permitted access shall be completed in accordance with the terms and conditions of the permit prior to being used for vehicular

access. In accepting the permit, the permit holder agrees to all terms and conditions of the permit.

Rule 2.5 Design and Placement Requirements

The design, location, construction and operation of driveways and related construction within road right of way shall meet requirements of the current ***Michigan Department of Transportation Standard Specifications for Construction*** and design standards set forth in Part 3 of these Rules and any other standards used by the Ingham County Road Commission.

Rule 2.6 Conditions of Issuance of Driveway Permits

All driveway permits issued in accordance with these rules shall be subject to the following conditions and limitations:

- (1) The Ingham County Road Commission reserves the right of inspection by its authorized representative of any driveway construction within the road right of way. The permit applicant shall reimburse the Road Commission for the services required for the review and approval of plans and for any on-the-job inspections that are required.
- (2) The Permit Department or its representative shall be given at least two days (excluding Saturdays, Sundays and Holidays) notice prior to the commencement of any operation covered by the permit.
- (3) The licensee shall have a copy of the permit available at the site during construction.
- (4) The licensee and applicant shall take, provide and maintain all necessary precautions to prevent injury or damage to persons and property from operations covered by the permit and shall use warning

signs and safety devices which are in accordance with the current ***Michigan Manual of Uniform Traffic Control Devices.***

(5) The licensee and applicant shall surrender the permit, cease operation and surrender all rights hereunder, whenever notified to do so by the Ingham County Road Commission because of its need for the right of way covered by the permit or because of a default of any conditions of the permit.

(6) The applicant shall furnish all materials and bear all costs of necessary construction, including tapers, widening, islands, pavement marking, signing, etc. within the Ingham County Road Commission right of way.

(7) Altered natural drainage shall not be permitted to flow onto road right of way unless the Ingham County Road Commission approves of any special provisions. **Road Commission road drainage facilities may not be used to drain storm water from private property.**

(8) The applicant shall remove all surplus materials to an area outside of the limits of the right of way unless the permit provides the manner of disposal at locations within the right of way. Excavated material shall not be stockpiled so as to adversely affect the safety of the traveling public.

(9) All work authorized by the permit shall be completed to the satisfaction of the Ingham County Road Commission on or before the completion date specified in the permit. Any request for an extension of time for completion of work, authorized by permit, shall include reasons for the request. Approval of extension of time shall be based on extenuating circumstances indicating no neglect on the part of the permit applicant.

Additional requirements may be imposed as a condition of an extension of time due to seasonal limitations and other considerations.

(10) It shall be the responsibility of the property owner or his/her agent to maintain all driveways connecting the property to the roadway, as well as those appurtenances set forth in the permit as related requirements, in a manner as not to damage, impair, interfere or obstruct a public road or create a foreseeable risk of harm to the traveling public. Maintenance of a road widening, such as deceleration lanes, acceleration lanes or passing lanes, which becomes part of the main roadway will not be the responsibility of the permit holder.

Rule 2.7 Indemnity and Certificates of Insurance

The licensee and applicant shall hold harmless, indemnify, defend and represent the Board and the Ingham County Road Commission, its officers and employees against any and all claims for damages arising from operations covered by the permit. Certificates of insurance shall be required on commercial driveways to ensure that the licensee and/or applicant can meet all claims, including damage or personal injury. General liability insurance carried by an applicant or licensee may be acceptable if it equals or exceeds current amounts specified by the Board. Insurance must be kept in force until the permitted construction is completed and approved. Failure to do so will be just cause for immediate suspension and/or cancellation of the permit.

Rule 2.8 Permit Deposits

(1) Should the proposed project for a commercial driveway involve road widening and/or the construction of enclosed storm drainage in the

road right of way, full time inspection may be required. In this case a deposit will be taken to cover all direct inspection costs. The amount of the deposit will be determined at the time of application based on the size and scope of the project.

(2) The Ingham County Road Commission will keep track of the actual inspection costs incurred by it in connection with each project. In the event the Road Commission's costs are less than the deposit, the excess will be returned to the owner. In the event that the Road Commission's costs are greater than the deposit, the owner will be billed for the deficiency. The Road Commission's objective is to recover the actual costs incurred.

Rule 2.9 Bonds

Bonds are required for all road cuts to protect the Ingham County Road Commission against the cost of completing construction or repairing deficiencies. Acceptable types of bonds are cash, certified or cashier's check, money order or irrevocable bank letter of credit, made payable to the Ingham County Road Commission. Surety bonds will not be accepted.

Rule 2.10 Appeals and Variance Procedures for Permit Applications

(1) Should the applicant object to a permit application denied by the Road Commission, or object to any of the terms or conditions of the permit placed therein by the Road Commission, a written appeal must be filed within 60 days of the transmittal of notice of denial or transmittal of the approved permit. The request shall include reasons for the appeal and may include recommendations by the applicant. The appeal, the permit application, supporting information, and a memorandum from the Road

Commission staff regarding the review process will be submitted to the Board for a final decision.

(2) The Board will review the request and the appeal and render a decision. At this final decision point, no other Road Commission employee will be authorized to approve the permit.

(3) If an applicant wishes to seek a variance from the standards of this regulation, a written request must be submitted as an attachment to the permit application form. The request for variance should include specific and documented reasons. The request and supporting documents should be submitted at the time of permit application. The Board will decide requests for a variance.

PART 3 – DRIVEWAY DESIGN STANDARDS

Rule 3.1 Number of Driveways

- (1) The number of access points to any property should be limited to one, unless it can be shown with an acceptable traffic engineering study that the property will generate sufficient traffic volumes to require two points of access, or that additional access points are necessary for safe internal operation on the property.
- (2) Each parcel should be permitted one access point, either contained wholly within the property frontage or as part of a joint access with an adjacent property. Additional points of access may be considered if adequate driveway spacing can be maintained (see Rule 3.6) and the following conditions apply:
 - (a) The average daily driveway volume is expected to exceed 5000 vehicles per day (vpd), or
 - (b) The expected peak hour driveway volume would exceed the acceptable level of service of a stop sign controlled intersection in accordance with the current edition of the Transportation Research Board *Highway Capacity Manual*, or
 - (c) A professionally prepared traffic analysis shows that more than one access point is needed to properly and safely serve the property.
 - (d) Corner lots may have access points on more than one street if warranted by a traffic analysis, subject to corner clearance criteria defined in Rule 3.8.

Rule 3.2 Number of Ingress Lanes

At driveways exceeding 1000 vpd and 40 right turn ingress movements during the peak hour, it may be desirable to provide an additional ingress lane, thereby widening the effective width of the throat to facilitate simultaneous left turn and right turn ingress movements.

Rule 3.3 Number of Egress Lanes

The number of lanes required to serve the exiting movements at a driveway location is a function of the number of vehicles expected to exit from the land use served by the driveway. Driveways should be designed with more than one egress lane if either of the following conditions are expected to be present:

- (a) The average daily egress traffic volume exceeds 1000 vehicles.
- (b) If more than 100 vehicles per hour (vph) are expected to turn left from the driveway during any hour and there are more than 500 vehicles on the street being entered.

Rule 3.4 One-Way Access

Access design of a one-way pair of driveways should be considered and is desirable if any of the following conditions are present or expected:

- (a) Roadway Average Daily Traffic (ADT) should be greater than 10,000.
- (b) The peak hour left turn volume into the driveway is expected to exceed 40 vehicles per hour (vph), and the property frontage exceeds 200 feet in length.

Rule 3.5 Driveway Locations

- (1) Driveways shall be so located that no undue interference with the free movement of road traffic will result, and to provide the required sight distance and the most favorable driveway grade.
- (2) Driveways shall not be constructed along the acceleration or deceleration lanes and tapers connecting to freeway interchange ramp terminals.
- (3) All non-commercial driveways on public roads outside of a Plat shall have a minimum of 165 feet of road frontage on the parcel served by the driveway. Access to land for agricultural purposes requires only a minimum road frontage of 66 feet, and the permit issued shall specify FOR AGRICULTURAL PURPOSES ONLY, provided, however, that if the parcel is developed in the future, the access road shall be built to county standards.

Rule 3.6 Commercial Driveway Spacing

- (1) Adjacent driveways should be spaced as far apart as access and the need for on-site circulation permit. Table 1 shows the desirable driveway spacing as a function of posted speed. The spacing in Table 1 reflects the impact lengths and influence areas associated with motorists entering or exiting a driveway, and are considered necessary to maintain safe traffic operations.

Table 1

Commercial Driveway Spacing

| POSTED SPEED LIMIT (MPH) | MINIMUM SEPARATION (FEET) |
|---------------------------------|----------------------------------|
| 25 | 105 |
| 30 | 125 |
| 35 | 150 |
| 40 | 185 |
| 45 | 230 |
| 50 | 275 |
| 55 | 330 |

(2) The minimum separation between adjacent driveways is measured from near edge to near edge.

(3) Distances between adjacent one-way driveways, with the inbound drive upstream from the outbound drive, can be one-half the distances shown above.

(4) In the event that a particular parcel, or parcels, lack sufficient frontage to maintain adequate spacing, the owner(s) have several options:

(a) The owner may seek a variance from the Road Commission from the desired spacing, but in no case can the variance be greater than the next lowest classification on Table 1. For example, on a 40 mph roadway requiring 185 feet of spacing between driveways, the distance may be reduced to no less than 150 feet, which is standard for a 35 mph roadway.

(b) The adjacent owners may agree to establish a common, shared, driveway. In such cases, the driveway midpoint should be the property line between the two parcels. The driveway must meet the standard

specifications, and the estimated driveway volume will be the sum of the trip generation rate of both land uses.

- (c) Provide an access point to the side street when it is possible.
- (d) After all options are exhausted, an access point may be allowed within the property limits as determined by the County Engineer.

Rule 3.7 Property Clearance

Property clearance is the distance between the property line of a parcel and the nearest driveway. The minimum property clearance distance should ideally be one-half of the driveway spacing requirements in Table 1 to ensure proper spacing. Should a property not be of sufficient frontage to provide this distance, joint access with an adjacent property should be pursued. Table 2 shows the minimum property clearance.

Table 2

Property Clearance

| CLASSIFICATION | PROPERTY CLEARANCE (FEET) |
|-------------------------|----------------------------------|
| Arterial | 75 |
| Collector | 50 |
| Local (Non Residential) | 25 |
| Local (Residential) | 10 |

Rule 3.8 Corner Clearance

- (1) Spacing between the intersection of two cross streets and an access driveway should be adequate to avoid having driveway conflict areas within the intersection of the two streets. The corner clearance

required is a function of the type of streets that intersect. Table 3 shows the minimum corner clearance.

Table 3 Corner Clearance

| CLASSIFICATION | INTERSECTING WITH | CLEARANCE (FEET) |
|-----------------------|--------------------------|-------------------------|
| Arterial | Arterial | 250 |
| | Collector | 125 |
| | Local | 50 |
| Collector | All | 50 |
| Local | All | 50 |

(2) Corner clearance is measured from the ultimate near cross street curb to the near driveway curb.

(3) If the property line is less than the distance from the corner to meet the minimum requirements, the driveway must be located within 10 feet of the property line away from the corner.

Rule 3.9 Clear Vision Areas

At intersections or railroad crossings where the Road Commission controls limited access right of way to provide a clear vision area, no driveway shall enter or cross any part of that clear vision area. Where an easement for a clear vision area has been provided at an intersection or railroad crossing, driveways shall not be permitted through the clear vision easement if another reasonable access point is available.

Rule 3.10 Buffer Areas

Adjacent to driveways, a buffer area between the right of way line and the pavement edge shall be used, as determined by the Ingham County Road Commission, to provide a physical barrier between moving traffic and private property. A buffer area is needed to provide an unobstructed vision area and to physically prohibit potentially hazardous movement of vehicles (especially at undesirable angles of approach) to and from the road. Where encroachment of parked vehicles takes place, or may take place, the Ingham County Road Commission may require this buffer area to be established by guardrail, guard posts, curb or equivalent method. In every case, an area of unobstructed vision shall be provided at either side of the driveways. This may require the removal of trees, earthen embankments and other obstructions.

Rule 3.11 Sight Distance

(1) To provide for adequate vision where the driveway intersects with the public roadway, all obstructions must be removed within the clear vision area. The driveway shall be constructed at a location along the property frontage that meets or exceeds the requirements of the **Intersection Sight Distance**, found in Tables 4, 5 or 6. Should this not be obtainable then the driveway shall be constructed at a location along the property frontage that meets the minimum requirements of the **Stopping Sight Distance**, found in Tables 4, 5 or 6.

(2) The recommended intersection sight distances are based on a 3.5 foot driver eye height and a 3.5 foot object height. Sight distance will be measured 18 feet from the edge of the traveled portion on gravel roads,

and 18 feet from the edge of pavement on paved roads. The distances shown in Tables 4, 5 and 6 are designed to enable vehicles exiting a private driveway, when turning left or right, to accelerate to the operating speed of the roadway without significantly interfering with the vehicles coming from either direction.

(3) The sight distances presented in Tables 4, 5 and 6 are valid when highway grades are between -3.0 percent and +3.0 percent. With roadway grades steeper than +/-3.0 percent, an adjustment can be made and will be evaluated by the County Engineer on an individual basis.

(4) Values for Tables 4, 5 and 6 are taken from the AASHTO manual, ***A Policy on Geometric Design of Highways and Streets, 2001, Fourth Edition.***

Table 4 Sight Distance

| Design Speed (mph) | Stopping Sight Distance (feet) | Intersection Sight Distance Onto Two – Lane Roads | | |
|--------------------|--------------------------------|---------------------------------------------------|--------------------------|--------------------------|
| | | Passenger Cars (feet) | Single Unit Truck (feet) | Combination Truck (feet) |
| 25 | 155 | 280 | 350 | 425 |
| 30 | 200 | 335 | 420 | 510 |
| 35 | 250 | 390 | 490 | 595 |
| 40 | 305 | 445 | 560 | 680 |
| 45 | 360 | 500 | 630 | 765 |
| 50 | 425 | 555 | 700 | 850 |
| 55 | 495 | 610 | 770 | 930 |

Table 5**Sight Distance**

| Design Speed (mph) | Stopping Sight Distance (feet) | Intersection Sight Distance Onto Four – Lane Roads | | |
|--------------------|--------------------------------|-------------------------------------------------------|--------------------------|--------------------------|
| | | Passenger Cars (feet) | Single Unit Truck (feet) | Combination Truck (feet) |
| 25 | 155 | 295 | 370 | 445 |
| 30 | 200 | 355 | 445 | 530 |
| 35 | 250 | 415 | 520 | 620 |
| 40 | 305 | 475 | 590 | 710 |
| 45 | 360 | 530 | 665 | 795 |
| 50 | 425 | 590 | 735 | 885 |
| 55 | 495 | 650 | 810 | 975 |

Table 6**Sight Distance**

| Design Speed (mph) | Stopping Sight Distance (feet) | Intersection Sight Distance Onto Five – Lane Roads | | |
|--------------------|--------------------------------|-------------------------------------------------------|--------------------------|--------------------------|
| | | Passenger Cars (feet) | Single Unit Truck (feet) | Combination Truck (feet) |
| 25 | 155 | 315 | 390 | 460 |
| 30 | 200 | 375 | 465 | 555 |
| 35 | 250 | 440 | 545 | 645 |
| 40 | 305 | 500 | 620 | 735 |
| 45 | 360 | 565 | 700 | 830 |
| 50 | 425 | 625 | 775 | 920 |
| 55 | 495 | 690 | 850 | 1015 |

(5) An access point shall be located at the point of maximum sight distance along a property frontage. Placement of a driveway on the inside of a horizontal curve along a roadway, or just below the high point of a crest vertical curve on a roadway shall be avoided.

(6) Access to property shall be denied when minimum safe sight distance cannot be attained. When access is denied, access may be allowed, at the owners expense, in one of the following ways:

(a) Negotiating with the adjacent property owners to acquire safe access to the subject parcel through easements.

(b) Constructing a frontage road serving the subject property and connecting with the roadway where safe access can be provided.

(c) Redesign or reconstruction of the existing roadway to correct the sight distance deficiency.

Rule 3.12 Driveway Dimensions and Details

The permit applicant shall indicate on the plan of the driveway layout requested, the number, type, dimension, location and spacing of the driveway(s). The County Engineer may approve the requested layout or may require changes so that the proposed layout will accommodate the vehicle normally expected without creating undue congestion or hazard on the highway. Exhibits 1 through 10 provide guidelines that shall be followed in the design and dimensioning of driveways in preparing plans for permit applications.

Rule 3.13 Commercial Driveways

(1) The permit application shall specify the driveway system requested, including the number and type (two-way, one-way, divided or directional) of driveways. The Ingham County Road Commission may approve the requested system, or may instruct the applicant as to changes to ensure the safe operation and necessary spacing between driveways, which will be based on anticipated traffic volumes on the driveway(s), on the existing traffic volumes on the road, type of traffic to use the driveway, type of roadside development and other safety and operational considerations.

(2) The maximum number of driveways from the property to each abutting road shall be as follows.

(a) One driveway may be permitted for each separately owned parcel with less than 100 feet of frontage, provided that the parcel is wide enough for the minimum driveway width plus the required radii, and meet the other requirements as necessary in these rules.

(b) Additional driveways may be permitted for commercial property with more than 100 feet of frontage, provided that the sum of the driveway widths of these additional driveways does not exceed 15 percent of the frontage in excess of the first 100 feet, and further provided that the traffic volume, safety and operational considerations are met as defined in these rules.

(c) The Ingham County Road Commission reserves the right to deny driveway access when such consideration would result in the driveway being a safety hazard.

(3) Two-way commercial driveways shall be designed to accommodate one lane of traffic in each direction. The dimensions of a two-way commercial driveway shall conform to those given in Exhibit 1, page 54.

(4) The dimensions of a one-way commercial driveway system shall conform to those given in Exhibit 2, page 55.

(5) A divided commercial driveway shall have a curbed island separating the entrance drive and the exit drive. The radii forming the edges on this island shall be designed to accommodate the largest vehicle that will normally use the driveway. The minimum area of the island shall be 50 square feet. The end of the island shall be even with, or beyond the right of way line. The dimensions of a divided commercial driveway shall conform to those given in Exhibit 3, page 56.

(6) Adjacent property owners may, and are encouraged, to consolidate their driveways by using either a joint driveway system or a frontage road. All frontage roads are to be placed on private property outside of the future right of way. If the Ingham County Road Commission approves such a system, a driveway permit shall be issued to all property owners concerned and shall state that there is an agreement that all properties shall have access to the road via the joint driveway and/or frontage road system. A copy of this agreement executed by all parties concerned shall accompany the application.

(7) For driveways on one-way roads, the dimensions given in this Rule may be altered so that the prohibited movements are discouraged. If the driveway system is to the left-hand side of a one-way road, the

dimensions used shall be based on the same principles as used on the right-hand side driveways.

(8) The permit applicant shall provide a deceleration lane and/or tapers as part of a commercial driveway if the driveway meets the warrants illustrated on Exhibit 4, page 57. Typical dimensions are shown in Exhibit 5, page 58. The anticipated peak hour right turns will be determined from the current edition of the Institute of Transportation Engineers ***Trip Generation Manual***.

(9) The permit applicant shall construct a passing lane on the side of the road directly opposite a proposed commercial driveway or other heavy traffic generator when warranted by the two-way 24-hour volume and the anticipated peak hour left turns from the road as determined by Exhibit 6, page 59. The anticipated peak hour left turns will be determined from the current edition of the Institute of Transportation Engineers ***Trip Generation Manual***.

(10) When other conditions such as horizontal and vertical sight distance, traffic signal location and other physical factors directly affect public safety, a passing lane shall be required. Minimum dimensions for a passing lane are shown on Exhibit 7, page 60.

(11) Directional commercial driveways are special cases, and the use of such driveway shall be considered on an individual bases. Directional driveways shall be designed to facilitate the desired turning movements and to discourage the prohibited movement. Radii shall be, as approved by the County Engineer, based on the intersecting angle and the turning path of the largest vehicle that will normally use the driveway.

Rule 3.14 Residential Driveways

(1) The number of residential driveways that may be permitted shall be determined as follows:

(a) All lots or parcels of land not in plats that are created after March 31, 1997, (the effective date of amendment to Public Act 288, of 1967, i.e. the Land Division Act) must have a minimum of 165 feet of road frontage for the issuance of a driveway permit. Access to land for agricultural purposes requires only a minimum of 66 feet of road frontage, PROVIDED, HOWEVER, that if the parcel is developed in the future, the access road shall be built to county standards.

(b) One residential driveway shall be permitted for each platted lot or for un-platted residential property with less than 100 feet of frontage and that existed as of March 31, 1997.

(c) Additional residential driveways may be permitted for residential property with more than 165 feet of frontage, PROVIDED that the sum of the driveway widths of these additional driveways does not exceed 15 percent of the frontage in excess of the first 100 feet.

(d) Two residential driveways may per be permitted on the same property, in lieu of the above, to serve a circle driveway if the frontage of the property is 165 feet or more.

(e) Residential driveways on the same property shall be at least 45 feet apart, center-to-center.

- (2) The dimensions of a residential driveway shall conform to those given on Exhibits 8 and 9, pages 61 and 62.

Rule 3.15 Field Entrances and Utility Structure Driveways

Field entrances may be permitted for cultivated land, timberland, or undeveloped land. The dimensions of a field entrance and of a utility structure driveway shall conform to those given on Exhibit 10, page 63.

Rule 3.16 Driveway Surfacing

- (1) When the road is paved:
 - (a) Commercial driveways shall be paved and curbed to the end of the radius plus ten (10) feet of tangent curb. If the road is uncurbed, the curb ending adjacent to the road shall be located 13.5 feet from the edge of the pavement to the back of the curb, and shall be parallel to the road.
 - (b) Residential driveways shall be paved between the edge of pavement and the existing sidewalk. If there is no existing sidewalk, the driveway shall be paved at least 10 feet from the edge of pavement. If the driveway is to be paved with concrete, the end of the driveway shall extend no closer to the road than two (2) feet from the edge of pavement; the distance between the end of the concrete driveway and the edge of pavement shall be paved with bituminous asphalt. Curb cuts or curb returns shall be constructed based on the current Ingham County Road Commission standards for curb and gutter.

- (2) When the road is unpaved:
 - (a) Commercial and residential driveways may be surfaced with stabilized gravel. The minimum requirement for commercial driveways is ten (10) inches of compacted stabilized aggregate, and the minimum requirement for residential driveways is six (6) inches of compacted stabilized aggregate.
 - (b) If driveways are paved, the paving shall extend no closer to the road than one (1) foot behind the driveway culvert location or five (5) feet from the edge of the road.
- (3) Field entrances and utility structure driveways may be surfaced with stabilized gravel and may be uncurbed. In certain locations, paving and curbing may be required on utility structure driveways.
- (4) The surface of paved commercial driveways, including tapers without right-turn lanes, shall be concrete or bituminous. The thickness of the surface and the base shall be sufficient to provide the bearing capacity needed to carry the proposed traffic loads. A five (5) inch (550 pounds per square yard) bituminous mix on eight (8) inches of compacted gravel and eight (8) inches of compacted sand, seven (7) inches of asphalt on existing soil, eight (8) inches of un-reinforced concrete on sand or equivalent surfacing material which meets current ***Michigan Department of Transportation Standard Specifications*** may be considered acceptable for normal commercial driveway traffic loads over stable soil.
- (5) Residential driveways may be paved with a design that is one-half the thickness requirements of commercial driveway.

(6) The pavement of all additional lanes and accompanying tapers shall be the same material as the pavement of the road unless the Ingham County Road Commission allows the use of an equivalent pavement. The cross-slope of all additional lanes and all tapers shall be a continuation of the cross-slope of the existing road pavement unless otherwise specified by the Ingham County Road Commission.

(7) The surface of the road shoulder adjacent to all additional lanes and tapers shall be of the same material as the surface of the existing road shoulder and shall conform to the current ***Michigan Department of Transportation Standard Specifications***. The shoulder area between adjacent commercial driveways serving the same property, which are less than 200 feet apart, (centerline to centerline) must be paved as directed by the county engineer.

Rule 3.17 Curbing

Curbing shall either be the same detail as the existing curb or shall conform to the current Ingham County Road Commission standards for curb and gutter.

(a) If the road is uncurbed, the grade of the driveway between the road edge of pavement and the edge of the shoulder shall conform to the slope of the shoulder.

(b) The curb height shall be tapered from full height at the edge of pavement to zero height at the sidewalk if the driveway grade meets the grade of an existing sidewalk.

Rule 3.18 Drainage

(1) The driveway, including any new lanes or tapers, shall be designed and constructed so that the drainage is not adversely affected. The drainage and the stability of the road subgrade shall not be altered by driveway construction or roadside development. The drainage of any new lanes or tapers shall be carried to the outside edge of the pavement.

(2) All culvert pipe used shall be of a size adequate to carry the anticipated natural flow of the ditch; the culvert size shall be determined by the Ingham County Road Commission and shall not be less than twelve (12) inches, inside diameter. Culvert pipe shall be CMP (corrugated metal pipe) with rolled edges. Flared end sections will be allowed where applicable. Catch basins, drainage channels and other drainage structures required within the road right of way shall be manufactured or constructed and installed in accordance with the current ***Michigan Department of Transportation Standard Specifications***. The minimum length of the culvert will be determined as the sum of the width of the driveway and the distance needed to provide slopes to adjacent fore slope and back slope; maximum slope of 1 on 2. The use of headwalls on culvert ends will not be permitted. The use of flared end sections is encouraged. Sod, riprap or other suitable material shall be placed at all culvert ends to prevent erosion.

(3) Adjacent right of way shall be graded and stabilized to provide for positive drainage away from the road. The drainage shall be accommodated outside of the paved portion and shoulder of the road.

Rule 3.19 Driveway Profile

- (1) If the road is uncurbed, the grade of the driveway between the road edge of pavement and the edge of the shoulder shall conform to the slope of the shoulder.
- (2) The grade of driveways connecting to curbed roads will be the grade required to meet the sidewalk elevation if the sidewalk is ten (10) feet or less from the road edge of pavement. The grade cannot exceed the maximums given in Rule 3.19 (3). If the driveway grade does exceed the allowable grade, the sidewalk shall be adjusted.
- (3) For uncurbed roads, if the sidewalk is more than ten (10) feet from the edge of pavement, or if there is no sidewalk:
 - (a) At a point twenty-five (25) feet from the edge of the shoulder, the grade of two-way, one-way and divided commercial driveways shall be within six (6) inches (2%) of the edge of shoulder grade. At a point seventy-five (75) feet from the edge of shoulder, the grade shall be within 4.5 feet (6%) of the edge of shoulder grade.
 - (b) At a point twenty-five (25) feet from the edge of pavement, the grade of residential and utility structure driveways and field entrances shall be within 2.5 feet (10%) of the edge of shoulder.
- (4) Vertical curves (15-foot minimum) shall be provided at all changes of grade of four (4) percent or more.
- (5) If the sidewalk elevation must be adjusted to meet the driveway, the slope of the sidewalk shall not exceed 3/8 inch per foot.

Rule 3.20 Parking and Storage

The Ingham County Road Commission will work closely with township officials and other local units of government, who have control of land use, to ensure that commercial establishments of a “drive-in” nature (drive-in restaurants, drive-in banks, auto washes, etc.) provide adequate on site storage off of the Road Commission right of way for vehicles waiting to be serviced since vehicle storage on highway lanes or shoulders create an unsafe condition and cannot be tolerated.

Rule 3.21 Traffic Signing

(1) The permit applicant shall provide, and properly maintain, temporary traffic signs and pavement markings that are necessary for the proper operation of the driveway. All signs and pavement markings shall conform to the current edition of the ***Michigan Manual of Uniform Traffic Control Devices***. The plans shall indicate the signing and pavement markings required.

(2) The Ingham County Road Commission will determine what permanent signs and markings are necessary for the public road system and install them at the expense of the applicant. Permanent signs and markings will be in conformity with the current edition of the ***Michigan Manual of Uniform Traffic Control Devices***.

Rule 3.22 Traffic Signals

(1) At high volume access facilities, traffic safety and operations may be enhanced by the installation of a traffic signal. These devices shall be used in accordance with the current edition of the ***Michigan Manual of Uniform Traffic Control Devices***.

(2) A traffic signal may be installed at the developer's expense, subject to approval by the Road Commission's County Engineer as part of an access facility, if the projected traffic generated by the development would meet the warrants established in the current edition of the ***Michigan Manual of Uniform Traffic Control Devices***. The traffic volumes generated by the development must be documented with a traffic impact study.

(3) The installation of a traffic signal shall require approval of the Road Commission's County Engineer. Although the warrants for the installation of a traffic signal may be satisfied, the Road Commission's County Engineer may determine that a traffic signal would be detrimental to coordinated traffic flow, result in undue delay, impair traffic operations, or impair traffic safety on the roadway. In this case, a traffic signal shall not be installed.

(4) The Road Commission's County Engineer shall approve the engineering plans for a traffic signal. The traffic signal shall be designed to the current ***Michigan Department of Transportation Standard Specifications***.

(5) All costs associated with a traffic signal installation shall be the sole responsibility of the developer. Prior to approval of an access facility with a traffic signal, the developer shall enter into a formal joint agreement with the Ingham County Road Commission. The joint agreement shall delineate the responsibilities of the Ingham County Road Commission and the responsibilities of the developer as related to the signal installation and maintenance costs. The responsibilities of the developer shall include, but

not be limited to, paying, or causing to be paid, all perpetual costs for the energy and maintenance of the traffic signal; paying, or causing to be paid, all costs for any future upgrading, revisions, modifications, and/or modernizations; and meeting other provisions related to the traffic signal installation. The ownership of the traffic signal shall rest with the Ingham County Road Commission. If a traffic signal is required to be a part of an interconnected traffic signal system, the developer shall also be responsible for all costs associated with the interconnection.

(6) Signalization of driveways should only be considered if driveway traffic volumes or past accident experience warrants installation. With the approval of the Road Commission's County Engineer, any warranted driveway signals may be located 600-700 feet from adjacent signals if the driveways served form a "T" intersection. Four-legged signalized driveway intersections should be avoided unless they are at least one-quarter mile from adjacent signals. Driveway signals should also be interconnected and coordinated with any other signals, either existing at the time the driveway signal is installed or added later, within 1,500 feet of the signalized driveway.

Rule 3.23 Traffic Impact Study

(1) A traffic impact analysis is a specialized traffic engineering study that accesses the effects that the traffic generated by a particular development will have on the surrounding transportation network. A traffic impact study will vary in range and complexity depending on the type and size of the proposed development.

(2) A traffic impact study will be required by the Ingham County Road Commission for the review of any driveway, or median access permit, or any development that could generate 100 or more peak-hour directional trips, or over 750 daily trips over a 24 hour period. The difference in traffic generated should be evaluated for its potential impact on the adjacent road system, including nearby intersections and at the access points of the development under consideration.

(3) A traffic impact “assessment” could be required for a project generating 50-99 peak hour directional trips. This type of study is recommended for smaller scale projects that should not have a significant impact on the overall road system, but will have impacts at the site access. The analysis for this type of study can typically be isolated to the turning movements at all site access points.

(4) The estimated trip generation for the site being reviewed must be based on one of two sources, 1) the current edition of the Institute of Transportation Engineers *Trip Generation* manual, or 2) local traffic data from similar sources.

(5) The Level of Service (LOS) should be evaluated for the critical movements at the site access points. Also, the traffic study should show the projected level of service for all movements at any signalized intersections and for all critical movements at unsignalized intersections. If the LOS of the existing intersections is a “C”, “D” or better, and the proposed project will produce a LOS of “E” or worse at one or more movements at a nearby intersection or a site access point, mitigation

needs to be evaluated. If the intersection LOS is currently an "E" or worse, the current LOS must be maintained or improved.

(6) The major benefit of a traffic impact study is to determine what, if any, mitigation measures are needed. The study should present mitigation alternatives and recommendations. Mitigation measures are not limited to physical improvements. Mitigation can include changes to traffic signal timing, or reducing the number of trips generated in the peak hour. Sample mitigation measures include, but are not limited to, the following;

(a) Roadway improvements

- construct a by-pass lane
- pave the roadway
- re-align the road
- improve the sight distance
- widen the road
- intersection improvements
- add deceleration/acceleration lanes
- add a traffic signal
- add a median crossover

(b) Access management techniques

- increase driveway spacing from intersections
- relocate driveway or intersection
- reduce the number of driveways
- install a median

- develop a service road system
 - share access with adjacent land
- (c) Operational improvements
- change signal timing or phasing
 - improve signal progression
 - reduce peak hour trips through transit
 - off-peak shift changes
- (d) Site plan/land use techniques
- reduce project size
 - modify project phasing
 - use of regulatory, directional signs and pavement markings
 - pedestrian or bicycle circulation
 - internal circulation
 - service vehicle/truck access or circulation

(7) The preparation of a thorough traffic impact study requires extensive background and experience in traffic related analysis. Therefore, the experience of the person preparing the traffic impact analysis best defines his or her ability to provide a technically sound analysis. The following are the requirements for the person preparing the traffic impact analysis that is to be submitted to the Ingham County Road Commission.

- (a) Three or more years of experience in preparation or review of traffic impact studies.

(b) Specific training and professional coursework in traffic impact analysis from an accredited college or university, or other transportation professional training organizations. Such as, but not limited to, the National Highway Institute, the Northwestern Traffic Institute or similar organizations.

(c) The person preparing the study shall be an associate (or higher) member of relevant professional organizations, particularly the Institute of Transportation Engineers, Transportation Research Board or other appropriate professional organizations. This helps ensure that the person preparing the traffic impact analysis is maintaining their knowledge as new research is published.

(d) The person preparing the traffic impact analysis should have one of the following professional qualifications, provided that any study involving design work and traffic operations analysis shall be prepared by or under the supervision of a Professional Registered Engineer (PE) with specific training in traffic engineering.

- A Registered Professional Engineer (PE), with training in traffic engineering.
- A community planner with an AICP, or
- A trained professional transportation planner.

(8) The study should include a resume of the person who prepared the traffic impact analysis and/or relevant experience of the firm responsible for the report. The study should also be signed by the person who prepared the study with full recognition of potential liability for the results and recommendations outlined in the report.

PART 4 – BANNER PERMITS

Rule 4.1 Authorized Applicants

A permit for the installation of banners to be placed within or over county road right of way may be issued by the Ingham County Road Commission only to the governing body of a city, incorporated village or township, pursuant to Act 200 of the Public Acts of 1969, as amended.

Rule 4.2 Application

Applications for permits for the erection of banners shall be in the manner prescribed by or on the appropriate forms supplied by the Permit Department.

Rule 4.3 Minimum Requirements

(1) Permit applications shall be accompanied by a copy of a resolution from the local governing body designating an authorized official of the city, village or township as having the authority to make the application for the city, village or township. The resolution must also indemnify and hold harmless the Ingham County Road Commission from all claims arising as a result of the permitted banner installation. The application should be submitted approximately one month in advance of the proposed installation.

(2) Each application shall include the following information:

(a) Activity in connection with which the banners are to be placed;

(b) Location of the proposed installation including distance to overhead traffic control devices;

- (c) A description of the banners, including any legend or symbol thereon;
- (d) The height of an overhead banner from the road surface to its lowest point.
- (e) The dates on which the banner will be erected and removed; this period shall not exceed a time period specified by the Ingham County Road Commission. An acceptable period of time for banners to be in place is three weeks, except for Christmas decorations that may be in place for six weeks.
- (f) Such other information as the Ingham County Road Commission may require.

Rule 4.4 Design and Placement Requirements

- (1) The design, method of installation and location of all banners shall be such that they will not be dangerous to those using the road or unduly interfere with the free movement of traffic.
- (2) Overhead banners shall be securely fastened and have a minimum bottom height of 18 feet above the surface of the road and be placed no closer than 100 feet on either side of traffic lights or signals and shall be placed so as not to obstruct a clear view of such traffic lights or signals or other traffic control devices. They shall not be attached to trees.
- (3) Banners shall not have displayed thereon any legend or symbol that may, in any way, be construed to advertise or otherwise promote the sale of or publicize any merchandise or commodity or which may be construed to be political in nature.

(4) Banners shall not have displayed thereon any device that is or purports to be or is an imitation of or resembles or which may be mistaken for a traffic control device or which attempts to direct the movement of traffic.

(5) Decorations shall not include flashing lights or other devices that may be distracting to motorists.

Rule 4.5 Conditions of Issuance of Banner Permits

(1) Permits for the erection or installation of banners may be cancelled by the Ingham County Road Commission if such installation shall become dangerous to those using the road or unduly interfere with the free movement of traffic.

(2) The city, village or township making application shall faithfully fulfill all permit requirements and shall indemnify and hold harmless the Board from claims of every kind arising out of operations by any permit or permits issued.

**PART 5 – ROAD CLOSURES FOR PARADES, CELEBRATIONS
FESTIVALS AND SIMILAR ACTIVITIES**

Rule 5.1 Authorized Applicants

A permit granting permission for the temporary closure of a county road for a reasonable length of time for a parade, celebration, festival or similar activity, or to use a county road as a detour for traffic around a parade, etc., on a non-county road, may be issued by the Ingham County Road Commission only to the governing body of a city, incorporated village or a township.

Rule 5.2 Application Forms

Application for permits to close or partially close, or use as a detour, a county road for a parade, celebration, festival or similar activity shall be in the manner prescribed by on the appropriate forms supplied by the Permit Department.

Rule 5.3 Minimum Requirements

(1) A copy of a resolution shall accompany permit applications from the city, village or township requesting permission for the road closure or partial closure or use as a detour. The resolution shall designate and authorize an appropriate official of the requesting government body to sign the permit documents on its behalf.

(2) The application shall include, but not be limited to, the following information:

(a) The nature of the activity for which the permit is requested,

- (b) The dates and times it is proposed to close and reopen the county road to traffic,
- (c) The roads to be closed and the limits for each road, between which the road is to be closed,
- (d) The proposed detour route or routes,
- (e) Such other information that may be useful to or requested by the Ingham County Road Commission.

Rule 5.4 Road Closure Permit Conditions

All permits allowing the closure or partial closure of a county road shall be issued subject to the following conditions:

- (a) The closure or partial closure of the road and the detour route selected shall allow for the safe and free movement of traffic,
- (b) A suitable alternate location is not available for the parade, celebration or festival that is more acceptable for traffic safety and offers less interruption of traffic.
- (c) Normally, closures or partial closures of roads shall be allowed during daylight hours only. In the special case where a temporary nighttime closure is permitted for a parade, celebration, festival or similar activity, all points of potential hazard and all barricades and warning traffic signs will be lighted at the applicant's expense, and such lighting must be in accordance with requirements and specifications of the current edition of the ***Michigan Manual of Uniform Traffic Control Devices***, and the Ingham County Road Commission.

(d) All traffic control devices installed in conjunction with the road closure or partial closure and the detour route shall conform to the provisions of the current edition of the ***Michigan Manual of Uniform Traffic Control Devices***.

(e) When a county road needs to be closed, and a detour route established, for the parade, celebration, festival or other activities on the road, the required traffic control devices will be furnished and installed by the Ingham County Road Commission, and all costs arising from the installation, maintenance and removal of such devices shall be borne by the applicant.

(f) The city, village or township making application shall faithfully fulfill all permit requirements and shall indemnify and hold harmless the Board from claims of every kind arising out of operations by any permit or permits issued.

(g) The applicant shall clean up any litter, debris, etc., occurring in the road right of way as a result of the permitted event at his/her own expense and within a reasonable time thereafter. In the event that the Ingham County Road Commission must do the cleanup work, the applicant shall reimburse the Ingham County Road Commission for the cost thereof.

EXHIBITS

Exhibit 1

Two-Way Commercial Driveway

| Design Features | | Standard | Range |
|---------------------|---|----------|---------------|
| Intersecting Angle | A | 90° | 60° to 120° |
| Driveway Width | B | 30 Ft. | 20 to 50 Ft. |
| Entering Radius | C | 25 Ft. | 15 to 35 Ft. |
| Exiting Radius | D | 25 Ft. | 10 to 35 Ft. |
| Throat Length | E | 50 Ft. | 30 to 200 Ft. |
| Total Opening B+C+D | R | 80 Ft. | 45 to 105 Ft. |

Note:

The "Standard" dimension shall be used unless the Permit Department specifies, or the applicant shows cause for, a different value. The "Range" in dimensions indicates the working values for each design feature.

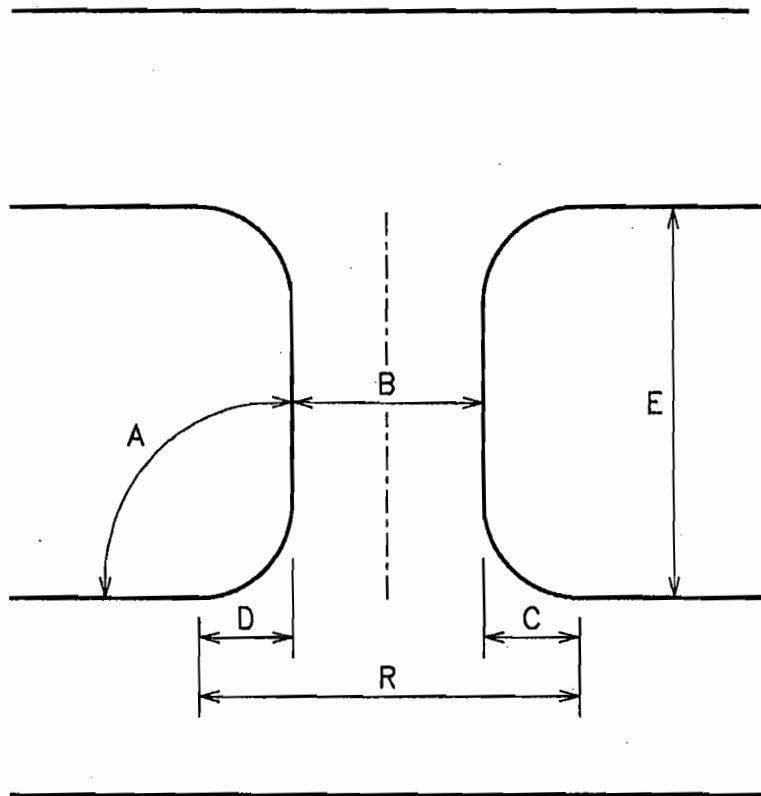

Exhibit 2

One-Way Commercial Driveway

| Design Features | | | Standard | Range |
|--------------------|-----------------|---|----------|--------------|
| Intersecting Angle | | A | 90° | 60° to 120° |
| Driveway Width | | B | 18 Ft. | 16 to 20 Ft. |
| One-Way IN | Entering Radius | C | 25 Ft. | 20 to 35 Ft. |
| | Exiting Radius | D | 5 Ft. | 5 to 10 Ft. |
| One-Way OUT | Entering Radius | C | 5 Ft. | 5 to 10 Ft. |
| | Exiting Radius | D | 25 Ft. | 20 to 35 Ft. |

Note:

The "Standard" dimension shall be used unless the Permit Department specifies, or the applicant shows cause for, a different value. The "Range" in dimensions indicates the working values for each design feature.

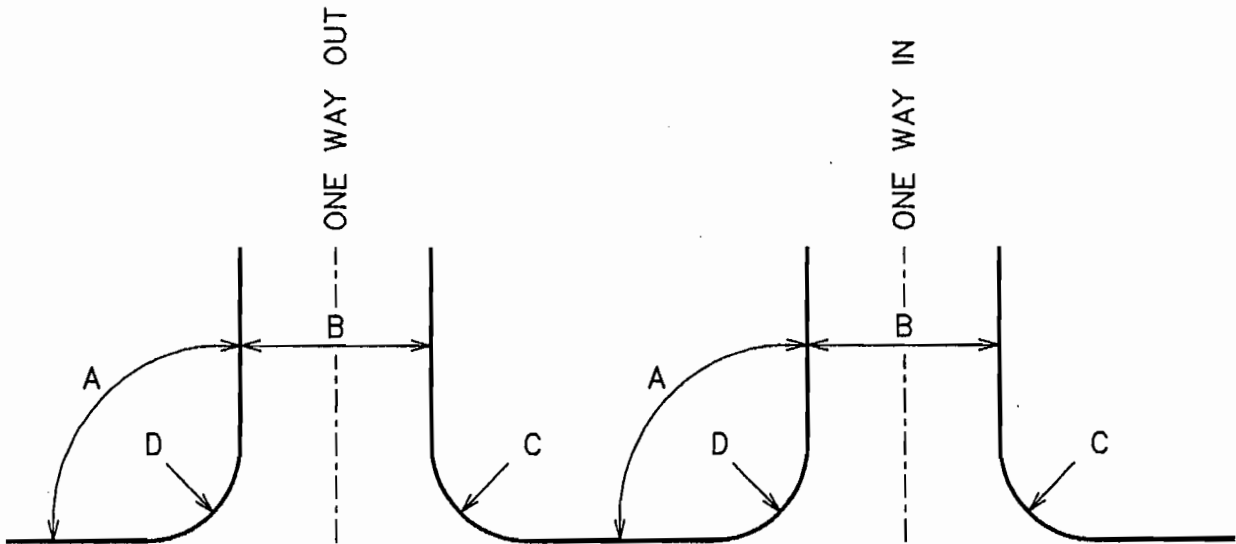

NOTE: See Rule 3.6 for spacing between one-way driveways

Exhibit 3

Divided Commercial Driveway

| Design Features | | Standard | Range |
|----------------------|---|----------|---------------|
| Intersecting Angle | A | 90° | |
| Driveway Width | B | 54 Ft. | 46 to 80 Ft. |
| Entering Radius | C | 25 Ft. | 15 to 35 Ft. |
| Exiting Radius | D | 25 Ft. | 10 to 35 Ft. |
| Entrance Drive Width | K | 22 Ft. | 20 to 28 Ft. |
| Exit Drive Width | L | 22 Ft. | 20 to 28 Ft. |
| Island Width | M | 10 Ft. | 6 to 24 Ft. |
| Island Length | N | 50 Ft. | 30 to 200 Ft. |
| Nose Offset | P | 12 Ft. | 6 to 18 Ft. |
| Total Opening B+C+D | R | 104 Ft. | 71 to 150 Ft. |

Note:

The "Standard" dimension shall be used unless the Permit Department specifies, or the applicant shows cause for, a different value. The "Range" in dimensions indicates the working values for each design feature.

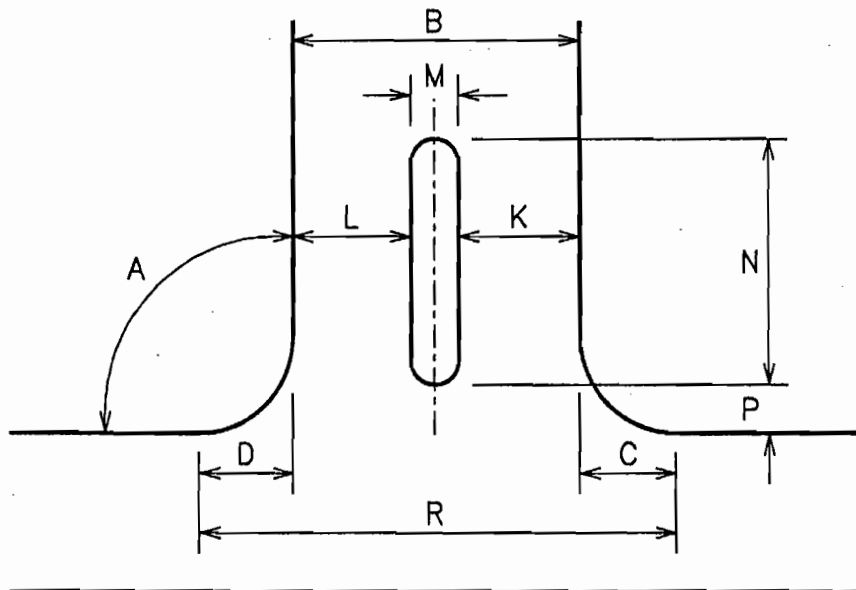

Warrants for Right Turn
Deceleration Lane or Taper

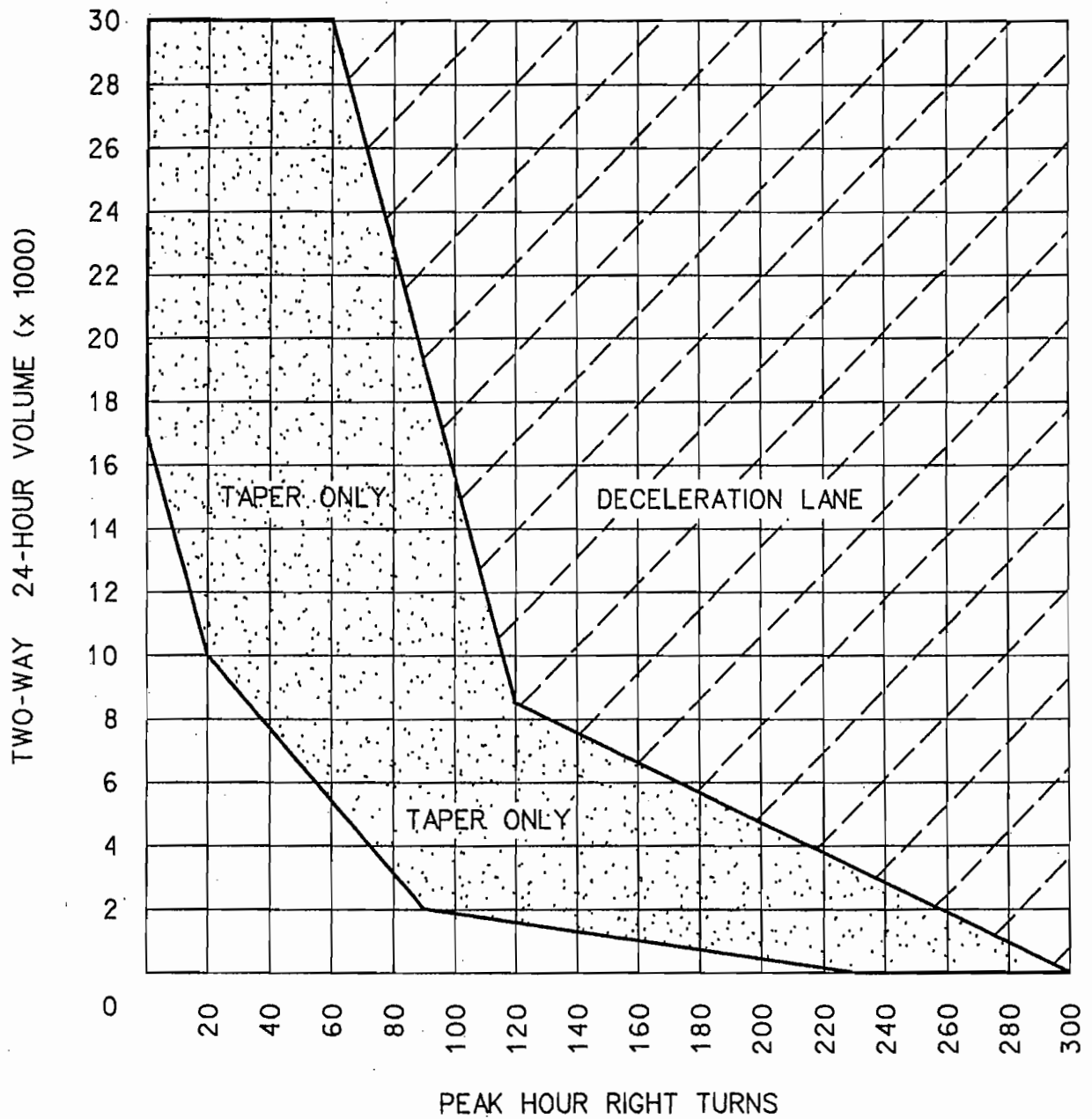

Exhibit 5

Commercial Right-Turn Lane and Taper

| Design Features | | Curbed Road | | Uncurbed Road | |
|------------------------------------|---|-----------------|--------------|-----------------|--------------|
| | | Standard (feet) | Range (feet) | Standard (feet) | Range (feet) |
| Curb Ending | E | Not Applicable | | 10 | |
| Right-Turn Lane Length | F | 25 | 0 to 150 | 25 | 0 to 150 |
| Entering Taper | H | 100 | 75 to 150 | 100 | 75 to 150 |
| Existing Lane Length | X | 25 | 0 to 100 | 25 | 0 to 100 |
| Exiting Taper | J | 75 | 50 to 100 | 75 | 50 to 100 |
| Pavement Width to Road Center-Line | G | 22 | 22 to 24 | 22 | 22 to 24 |

Note:

The "Standard" dimension shall be used unless the Permit Department specifies, or the applicant shows cause for, a different value. The "Range" in dimensions indicates the working values for each design feature.

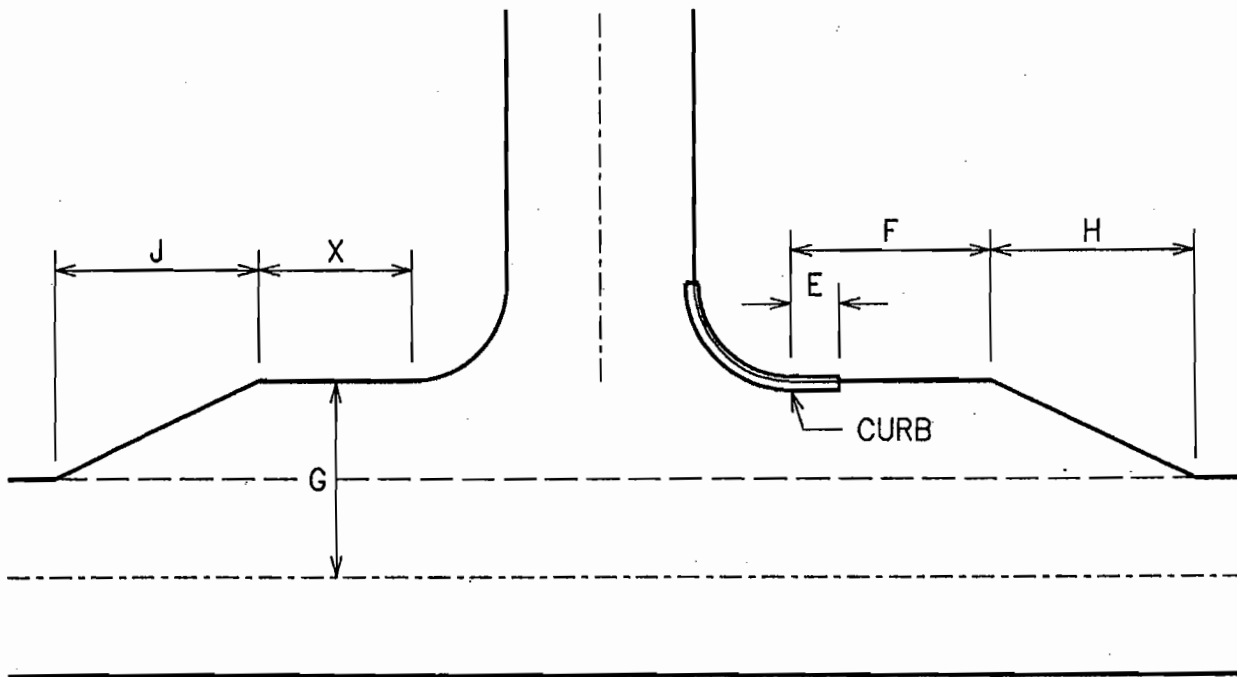

Warrants for Left Turn
Passing Lane

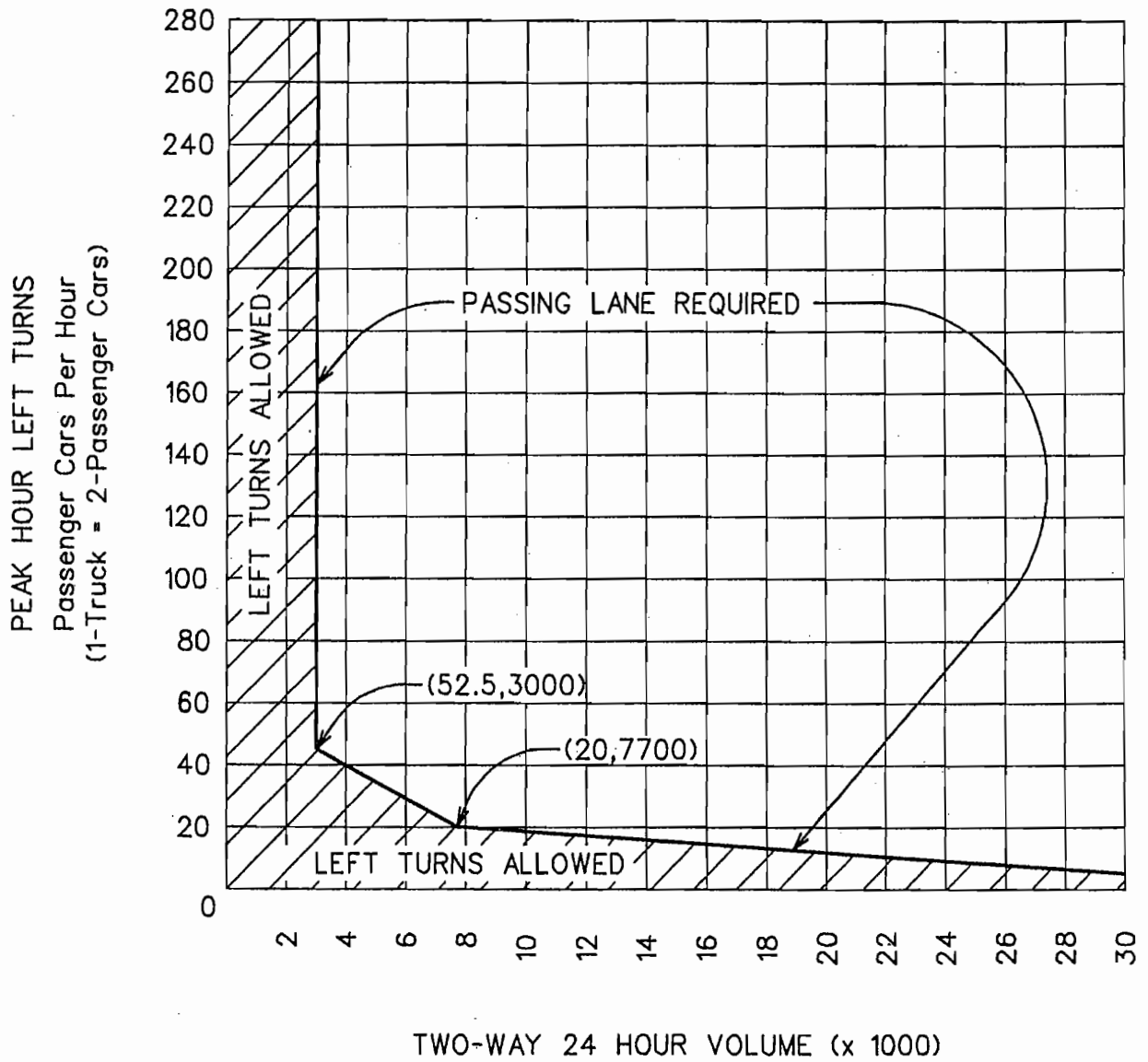

Exhibit 7

Passing Lane

| Design Features | | Standard | Range |
|------------------------------------|---|-----------------|----------------|
| Approaching Taper | V | See Taper Table | 50 to 225 Ft. |
| Departing Taper | W | 225 Ft. | 225 Ft. |
| Approaching Lane Length | S | 150 Ft. | 100 to 200 Ft. |
| Departing Lane Length | T | 50 Ft. | 50 to 100 Ft. |
| Pavement Width to Road Center-Line | G | 22 Ft. | 22 to 24 Ft. |

Note:

The "Standard" dimension shall be used unless the Permit Department specifies, or the applicant shows cause for, a different value. The "Range" in dimensions indicates the working values for each design feature.

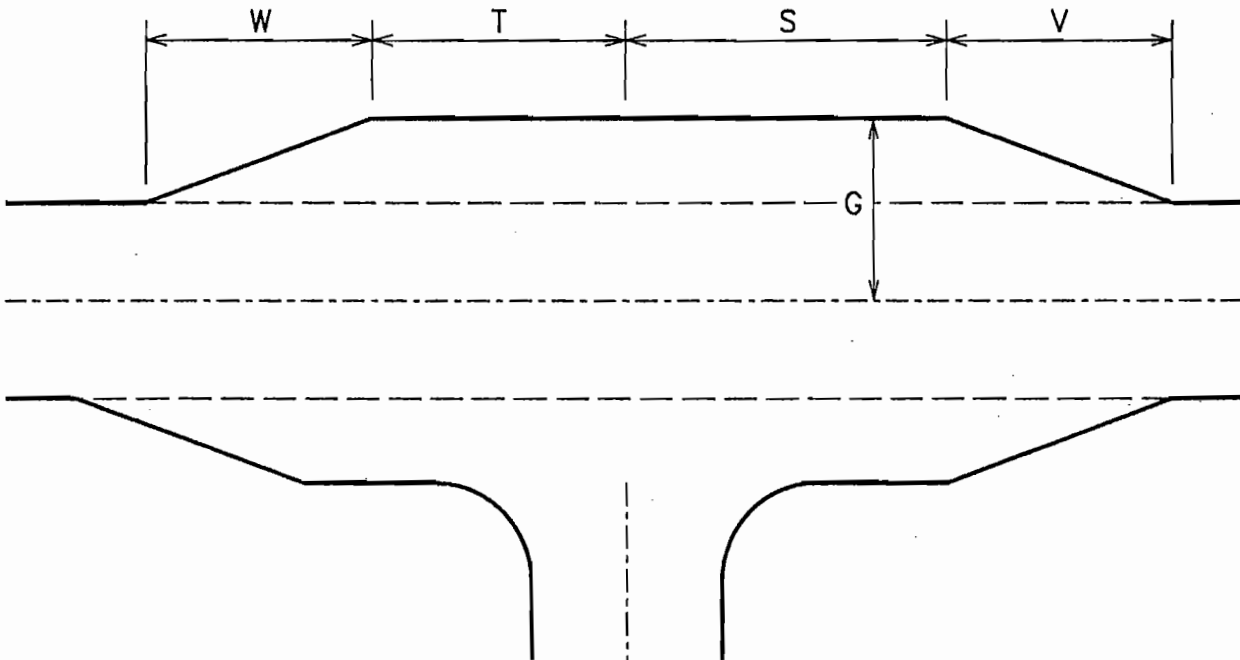

Taper Table

| | | | | | | |
|--------------|----|----|-----|-----|-----|-----|
| MPH | 30 | 35 | 40 | 45 | 50 | 55 |
| Taper (feet) | 50 | 75 | 100 | 130 | 180 | 225 |

Exhibit 8

Residential Driveway

| Design Features | | Standard | Range |
|---------------------|---|----------|--------------|
| Intersecting Angle | A | 90° | 70° to 110° |
| Driveway Width | B | 12 Ft. | 10 to 25 Ft. |
| Entering Radius | C | 10 Ft. | 2 to 15 Ft. |
| Exiting Radius | D | 10 Ft. | 2 to 15 Ft. |
| Total Opening B+C+D | R | 32 Ft. | 14 to 55 Ft. |

Note:

The "Standard" dimension shall be used unless the Permit Department specifies, or the applicant shows cause for, a different value. The "Range" in dimensions indicates the working values for each design feature.

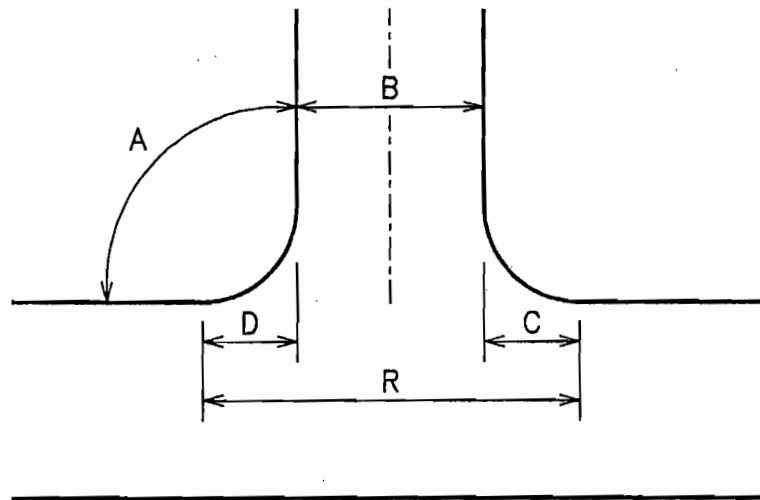

Residential Driveway - Subdivision

| Design Features | | Standard | Range |
|----------------------|---|----------|--------------|
| Intersecting Angle | A | 90° | 70° to 110° |
| Driveway Width | B | 12 Ft. | 10 to 25 Ft. |
| Entering Taper Width | C | 6 Ft. | 2 to 15 Ft. |
| Exiting Taper Width | D | 6 Ft. | 2 to 15 Ft. |
| Taper Depth | Q | 10 Ft. | 10 to 20 Ft. |
| Total Opening B+C+D | R | 24 Ft. | 14 to 55 Ft. |

Note:

The "Standard" dimension shall be used unless the Permit Department specifies, or the applicant shows cause for, a different value. The "Range" in dimensions indicates the working values for each design feature.

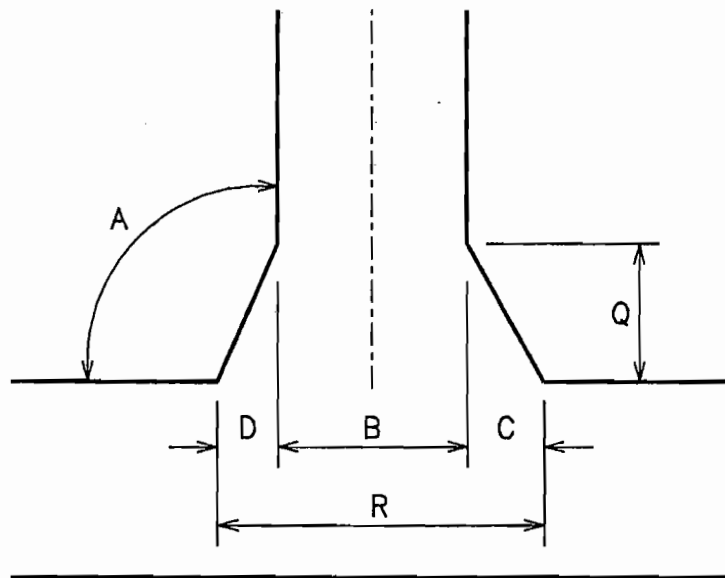

Field Entrance and Utility Structure Driveways

| Design Features | | Standard | Range |
|---------------------|---|----------|---------------|
| Intersecting Angle | A | 90° | 70° to 110° |
| Driveway Width | B | 16 Ft. | 12 to 35 Ft. |
| Entering Radius | C | 10 Ft. | 5 to 35 Ft. |
| Exiting Radius | D | 10 Ft. | 5 to 35 Ft. |
| Total Opening B+C+D | | 36 Ft. | 22 to 105 Ft. |

Note:

The "Standard" dimension shall be used unless the Permit Department specifies, or the applicant shows cause for, a different value. The "Range" in dimensions indicates the working values for each design feature.

